

R-Mer® Span I-Span Anchor Clip

Continuous Clip for the R-Mer Span Standing Seam Roof System



OVERVIEW & FEATURES

R-Mer Span I-Span Anchor Clip provides optimized performance in the toughest negative wind uplift pressure environments. Constructed on extruded 6005-T5 aluminum, this is a specialty accessory to the R-Mer Span Standing Seam Roofing system. It may be used instead of the standard 16 Gauge one piece clips in applications over Z-Channels or open framing, or anywhere severe loading drives the need for enhanced attachment.

DESIGN CHARACTERISTICS

- Available in standard lengths of 18' or 20'
- Maximum allowable span of 8'
- May be used in conjunction with standard, one piece clips

FEATURES AND BENEFITS

High-Performance Materials- The R-Mer Span I-Span Continuous Clip is made from lightweight but tough, extruded aircraft grade aluminum alloy 6005-T5.

Simplify Retrofit Applications- I-Span may eliminate the need to add expensive framing to an existing building in a roof retrofit project.

Strengthens the Roof System without Taking Away from Aesthetics- I-Span enhances the wind uplift capacity along the vulnerable roof perimeter, invisibly, from inside the seam. This eliminates the use of unsightly wind clamps on the roof panel seams.

Engineering Design- Garland will design the proper usage of the R-Mer Span Continuous Clip based on the specifics of the particular roof.

R-MER SPAN CONTINUOUS CLIP

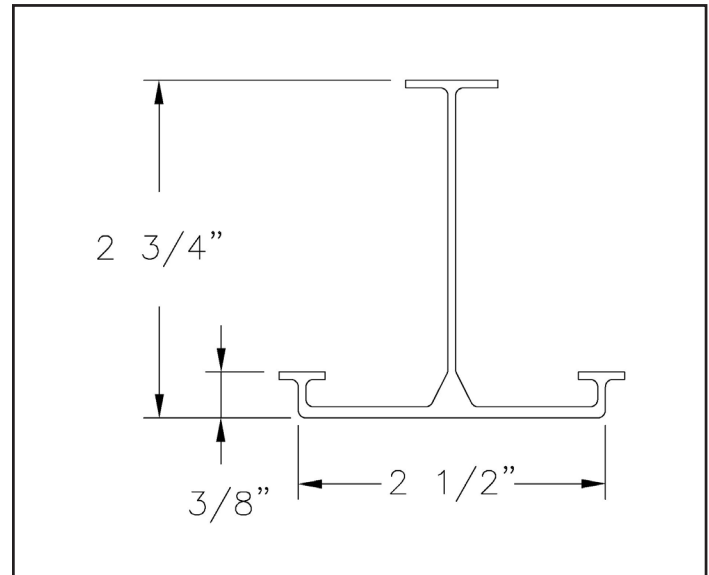

Technical Data	R-Mer Span Anchor Clip
Alloy	6005-T5
Wall Thickness	0.062" U.O.N.
Radius	0.062 ±0.016 (typ)
Area	0.563 sq. in.
Weight	0.66 lbs./ft.
Die Size	6 in.
Corners	.016" (typ)



R-Mer Span I-Span Anchor Clip is protected by U.S. 6,354,045 and Canada 2,334,538

For more information, visit us at: www.garlandco.com

The Garland Company, Inc.
3800 East 91st Street
Cleveland, OH 44105
FAX: 216-641-0633
Phone: 216-641-7500
Toll Free: 800-321-9336

Garland Canada Inc.
209 Carrier Drive
Toronto, Ontario
Canada, M9W 5Y8
FAX: 416-747-1980
Phone: 416-747-7995
Toll Free: 800-387-5991
(Only in Canada)

The Garland Company UK, LTD
Second Way Centre, Second Way
Avonmouth, Bristol UK BS11 8DF
Phone: 011 44 1174 401050 (Outside UK)
Toll Free: 0800 328 5560 (Only in UK)

Tests verified by independent laboratories. Actual roof performance specifications will vary depending on test speed and temperature. Data reflects samples randomly collected. A ± 10% variation may be experienced. The above data supersedes all previously published information. Consult your local Garland Representative or Garland Corporate Office for more information.

R-Mer and Garland Greenhouse are registered trademarks of The Garland Company, Inc. and Garland Canada Inc. Kynar is a registered trademark of Elf Atochem North America Inc. LEED is a registered trademark of the U.S. Green Building Council.