

VERTICAL SURFACES

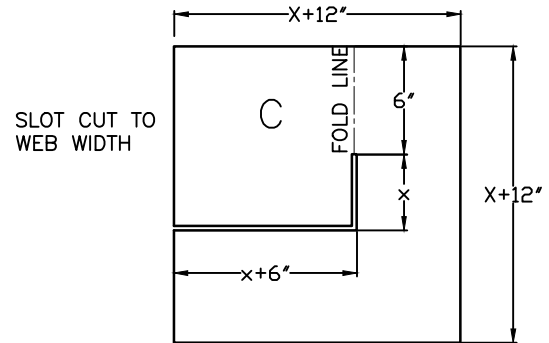
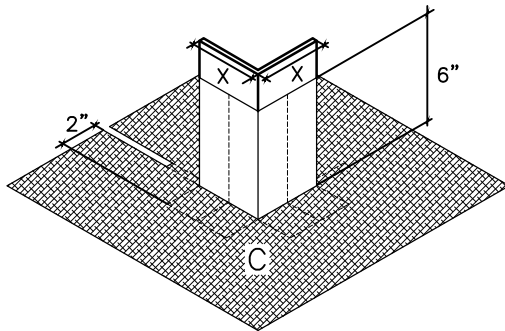

NOTES:

- A. USE REINFORCEMENT DETAIL IN CONJUNCTION WITH THE TUFF-FLASH PLUS LO LAYOUT DRAWING.
- B. EMBED ALL PRE-CUT FABRIC INTO A FULL WET BASE COAT OF TUFF-FLASH PLUS LO.
- C. ENCAPSULATE ALL FABRIC COMPLETELY WITH A MINIMUM OF A 48 MIL TOPCOAT.

HORIZONTAL SURFACES



THE GARLAND COMPANY, INC.
 GARLAND CANADA, INC.
 THE GARLAND COMPANY UK, LTD

ANGLE IRON SCRIM DETAIL

TUFF-FLASH PLUS LO FLASHING SYSTEM