

OVERVIEW & FEATURES

R-Mer Span is a structural standing seam roof system. R-Mer Span consists of a unique profile containing mesas throughout the panel to minimize "oil canning." The 2 3/8" high vertical seam makes R-Mer Span aesthetically pleasing and also the ideal roof system to withstand the most severe weather conditions. The heavy-duty continuous clip allows for unlimited expansion and contraction. R-Mer Span can be used on slopes down to 1/4" per foot for both retrofit and/or new construction.

PANEL PROFILE

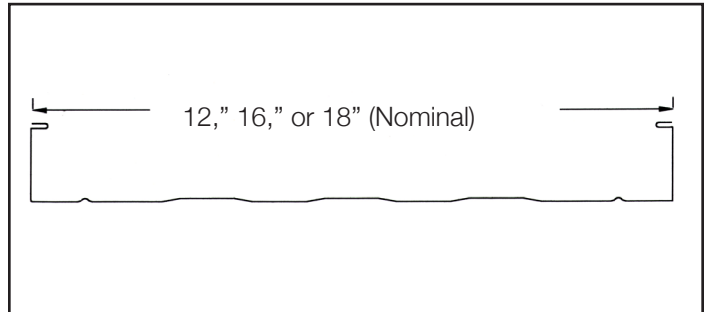

STANDARD CLIP

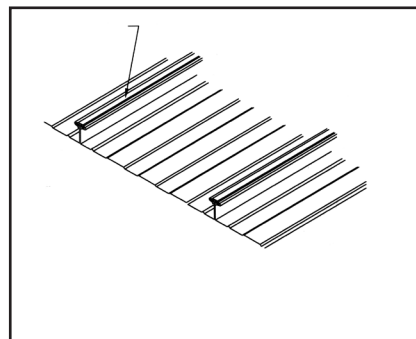

SEAM DETAIL AND ASSEMBLY

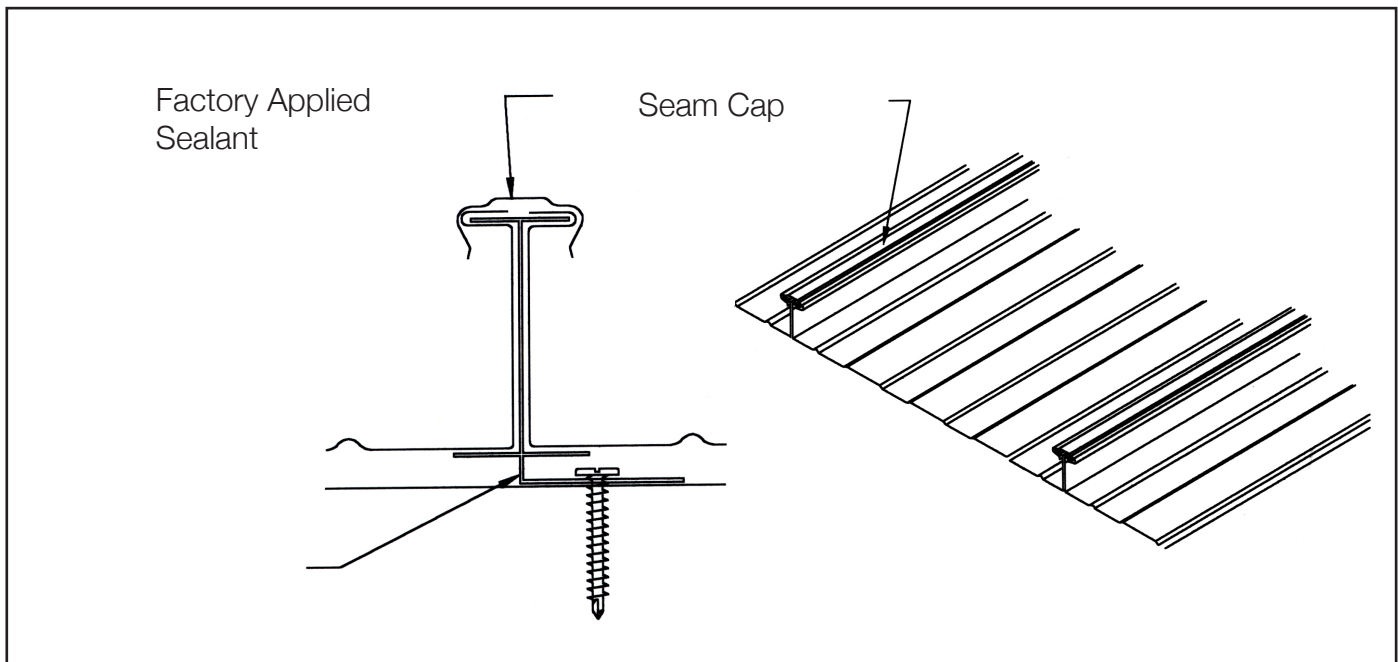



DESIGN CHARACTERISTICS

- Heavy-duty, 16-gauge, one-piece clip design provides for unlimited thermal movement
- Symmetrically designed panel/cap configuration contains four (4) layers of steel
- Double bead of factory applied hot melt sealant (water barrier) is completely isolated from clip
- 2-3/8" High vertical seam
- Tightest curving capability in industry for structural panel (Steel - 20 ft. radius; Aluminum - 10 ft. radius)
- Available for tapered panel applications
- Profile contains unique mesas or striations to minimize appearance of "oil canning"
- Spanning capability over open purlins on slopes down to 1/4:12
- 3/8" high clearance between panel and substrate helps ventilation and reduces possibility of condensation
- Ideal for retrofits over existing single plies, BUR's, modified bitumens or other metal roofs
- 20 and 30 year warranty available
- Available in 12", 16" or 18" wide panels
- Available in 20, 22 or 24 gauge G-90 Galvanized steel; .032, .040, or .050 aluminum, copper, stainless steel and zinc
- Available in a wide choice of colors

TEST CLASSIFICATIONS

- FM Class 1-195 in accordance with 4471 test procedure (12" widepanel; 22 gauge steel)
- UL 90 classification in accordance with UL 580 test procedure
- Class A fire rating in accordance with UL 790
- UL 263 fire assembly tested
- Roof system compliance with ASTM E 1592
- Air infiltration test in accordance with ASTM E 283 and E 1680
- Water penetration test in accordance with ASTM E 331 and E 1646

COLORS

Please contact your local Garland Representative for the available colors including those that are CRRC® qualified*.

For specific application recommendations and coverage rates, please contact your local Garland Representative or Garland Technical Service Department.



0700-0028

*based on qualified colors

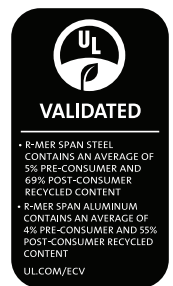

The Continuous Clip product used with R-Mer Span is protected by U.S. Patent # 6,354,045 and Canada Patent # 2,334,538

For more information, visit us at: www.garlandco.com

The Garland Company, Inc.
 3800 East 91st Street
 Cleveland, OH 44105
 FAX: 216-641-0633
 Phone: 216-641-7500
 Toll Free: 800-321-9336

Garland Canada Inc.
 209 Carrier Drive
 Toronto, Ontario
 Canada, M9W 5Y8
 FAX: 416-747-1980
 Phone: 416-747-7995
 Toll Free: 800-387-5991
 (Only in Canada)

Tests verified by independent laboratories. Actual roof performance specifications will vary depending on test speed and temperature. Data reflects samples randomly collected. A ± 10% variation may be experienced. The above data supersedes all previously published information. Consult your local Garland Representative or Garland Corporate Office for more information.

R-Mer is a trademark of The Garland Company, Inc. and Garland Canada Inc.
 Kynar is a registered trademark of Elf Atochem North America Inc.
 The CRRC mark is a registered trademark of the Cool Roof Rating Council.